

# NÝTY PRO SPECIÁLNÍ APLIKACE

## BULBEX Série BF01

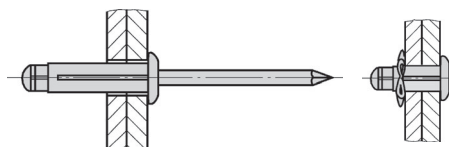

Nýtování plastů, pryže, překližky, sololitu, lepenky, plechů a kombinací těchto materiálů.

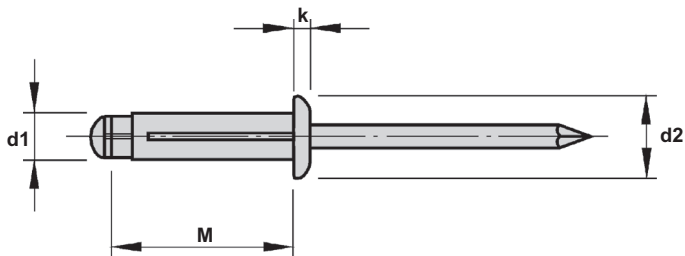

Všechny rozměry v mm.

d1 Ø	Ø : 4.2 - 4.5	M		Objednací číslo
		↑ ↓	[+1/-0.2]	
<b>4.0</b>	d2 Ø : 8.2	1.0- 3.0	16.0	BF010516
	k : 1.6	1.0- 7.0	21.2	0523
	⊕ : 1000 N	1.0- 8.5	22.9	0525
	⊖ : 600 N	5.0-12.0	27.6	0531

Všechny rozměry v mm.

d1 Ø	Ø : 5.0 - 5.2	M		Objednací číslo
		↑ ↓	[+1/-0.2]	
<b>4.8</b>	d2 Ø : 10.1	1.0- 4.0	18.3	BF010619
	k : 2.1	1.0- 9.0	23.3	0625
	⊕ : 1100 N	4.0-12.0	27.1	0630
	⊖ : 800 N			

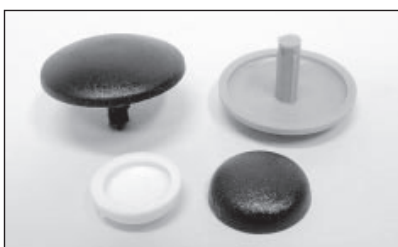

Plastové krytky na zvl. poptávku.

## HSN Série 1803



Nýtování bez A2 [1.4301] potřeby nýtovačky.

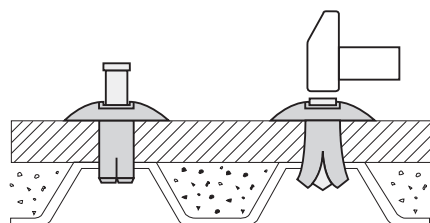
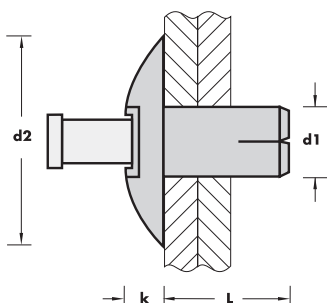

Všechny rozměry v mm.

d1 Ø	Ø : 4.9	L		Objednací číslo
		↑ ↓	[+1/-0.2]	
<b>4.8</b>	d2 Ø : 16 [+/-0.4]	4.5- 7.0	9.0	18034809
	k : 2.6 [+/-0.3]	11.5-13.0	16.0	4816
	⊕ : 2950 N	15.5-17.0	20.0	4820
	⊖ : 4900 N	20.5-22.0	25.0	4825
		25.5-27.0	30.0	4830
		30.5-32.0	35.0	4835
		35.5-37.0	40.0	4840
		40.5-42.0	45.0	4845
	45.5-47.0	50.0	4850	

# T-LOK Série BM01

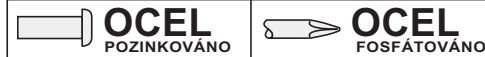

## ROZPĚRNÝ NÝT

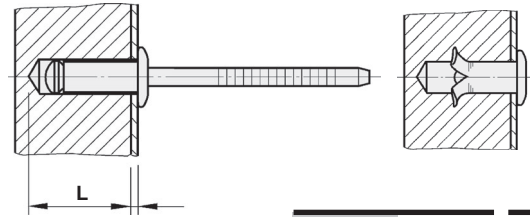
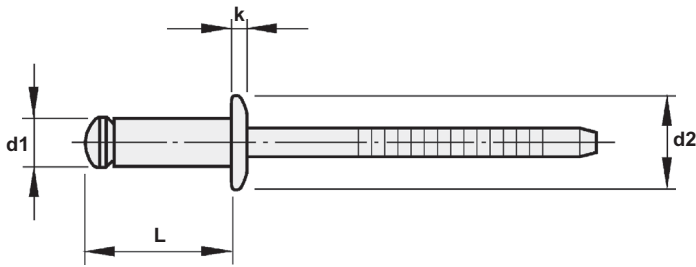

Všechny rozměry v mm.

			L*	Objednáací číslo
			[+1/-0.2]	
d1 Ø	Ø : 4.3 - 4.4	0.25-1.30	11.2-12.2	BM010510
d2 Ø	: 8.2	0.25-1.30	13.0-13.7	0512
k	: 1.3	0.25-7.60	12.7-20.1	0520
	: 500-700 N	0.25-9.14	12.7-21.6	0522
* závisí na svěrné tloušťce				
(hodnoty závisí na délce nýtu)				
: -				

**4.3**

+0.05  
-0.15

Všechny rozměry v mm.

			L*	Objednáací číslo
			[+1/-0.2]	
d1 Ø	Ø : 4.8 - 4.9	0.25-3.00	10.4-15.7	BM010614
d2 Ø	: 10.2	0.25-7.60	13.0-20.3	0620
k	: 2.1	* závisí na svěrné tloušťce		
	: 1000 N			
: -				

**4.8**

+0.05  
-0.15

# T-LOK Série 1301



## ROZPĚRNÝ NÝT

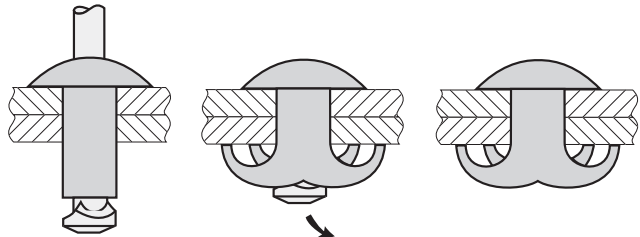
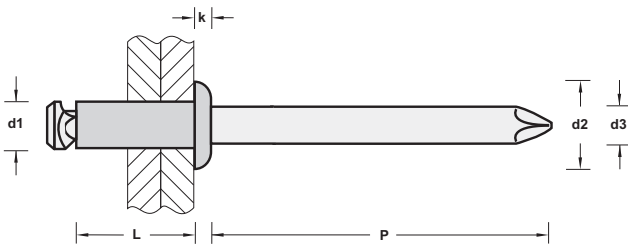

Všechny rozměry v mm.

			L	Objednáací číslo
			[+1/-0.2]	
d1 Ø	Ø : 3.7 max.	0.5- 1.0	8.0	13013208
d2 Ø	: 6.5 [+/-0.3]	1.0- 3.0	10.0	3210
k	: 1.0 [+/-0.2]	3.0- 5.0	12.0	3212
P	: ≥27	7.0- 9.0	16.0	3216
d3	: ~1.8	9.0-11.0	18.0	3218
	: 750 N			
	: 820 N			

**3.2**

+0.08  
-0.15

Všechny rozměry v mm.

			L	Objednáací číslo
			[+1/-0.2]	
d1 Ø	Ø : 4.5 max.	1.5- 5.0	10.0	13014010
d2 Ø	: 8.0 [+/-0.4]	4.0- 6.5	12.0	4012
k	: 1.2 [+/-0.2]	6.0- 9.0	14.0	4014
P	: ≥27	8.0-11.0	16.0	4016
d3	: ~2.1	10.0-13.0	18.0	4018
	: 1140 N	12.0-15.0	20.0	4020
	: 1280 N	15.0-20.0	25.0	4025
20.0-25.0 30.0 4030				

**4.0**

+0.08  
-0.15

Všechny rozměry v mm.

			L	Objednáací číslo
			[+1/-0.2]	
d1 Ø	Ø : 5.3 max.	1.5- 4.0	10.0	13014810
d2 Ø	: 9.0 [+/-0.4]	2.0- 6.0	12.0	4812
k	: 1.4 [+/-0.2]	4.0- 8.0	14.0	4814
P	: ≥27	6.0-10.0	16.0	4816
d3	: ~2.7	8.0-12.0	18.0	4818
	: 2450 N	10.0-14.0	20.0	4820
	: 2100 N	12.0-16.0	22.0	4822
16.0-19.0 25.0 4825				
19.0-24.0 30.0 4830				
24.0-29.0 35.0 4835				
29.0-34.0 40.0 4840				

**4.8**

+0.08  
-0.15

NÝTY PRO SPECIÁLNÍ APLIKACE

# RÝHOVANÝ NÝT Série 1601



ČSN 02 2391, DIN 7337

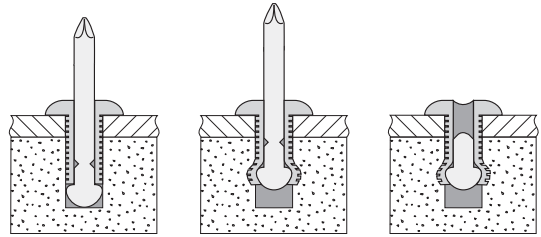
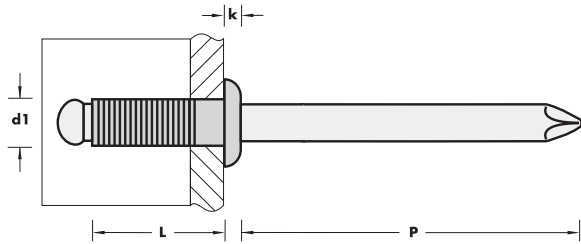

Všechny rozměry v mm.

d1 Ø	Ø  : 3.4
<b>3.2</b>	d2 Ø : 6.0 [+/-0.24]
	k : ≤1.4
	P : ≥26
+0.35	d3 : 1.8
-0	: 930 N
	: 525 N

	L	Objednáací číslo
	[+1/-0.2]	
max. 6.0	10.0	16013210
max. 10.0	14.0	3214

Všechny rozměry v mm.

d1 Ø	Ø  : 5.1
<b>4.8</b>	d2 Ø : 9.5 [+/-0.3]
	k : ≤2.0
	P : ≥27
+0.35	d3 : 2.65
-0	: 1575 N
	: 1185 N

	L	Objednáací číslo
	[+1/-0.2]	
max. 2.0	8.0	16014808
max. 6.0	10.0	4810
max. 7.0	11.0	4811
max. 8.0	12.0	4812
max. 10.0	14.0	4814
max. 12.0	16.0	4816
max. 14.0	18.0	4818
max. 16.0	20.0	4820
max. 21.0	25.0	4825
max. 26.0	30.0	4830

Všechny rozměry v mm.

d1 Ø	Ø  : 4.3
<b>4.0</b>	d2 Ø : 8.0 [+/-0.3]
	k : ≤1.7
	P : ≥27
+0.35	d3 : 2.2
-0	: 1410 N
	: 885 N

	L	Objednáací číslo
max. 4.0	8.0	16014008
max. 6.0	10.0	4010
max. 8.0	12.0	4012
max. 10.0	16.0	4016

# TLR Série 3904-A



Vodotěsný nýt pro střešní konstrukce, opláštění budov a transportní techniky.

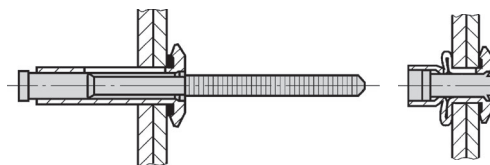
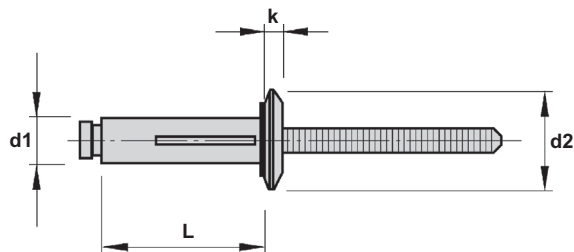

Všechny rozměry v mm.

d1 Ø	Ø  : 5.3 - 5.6
<b>5.2</b>	d2 Ø : 11.5
	k : 2.5
	: 2000 N
	: 3000 N

	L	Objednáací číslo
0.5 - 4.8	17.5	39045217
1.5 - 6.4	19.1	5219
4.7 - 9.6	22.2	5222
7.9 - 12.7	25.4	5225
11.1 - 15.9	28.6	5228

Všechny rozměry v mm.

d1 Ø	Ø  : 6.4 - 6.7
<b>6.3</b>	d2 Ø : 14.4
	k : 3.0
	: 3000 N
	: 4900 N

	L	Objednáací číslo
1.5 - 6.4	20.0	39046320
6.4 - 12.7	27.0	6327

NÝTY PRO SPECIÁLNÍ APLIKACE